

X-B, X-BLT

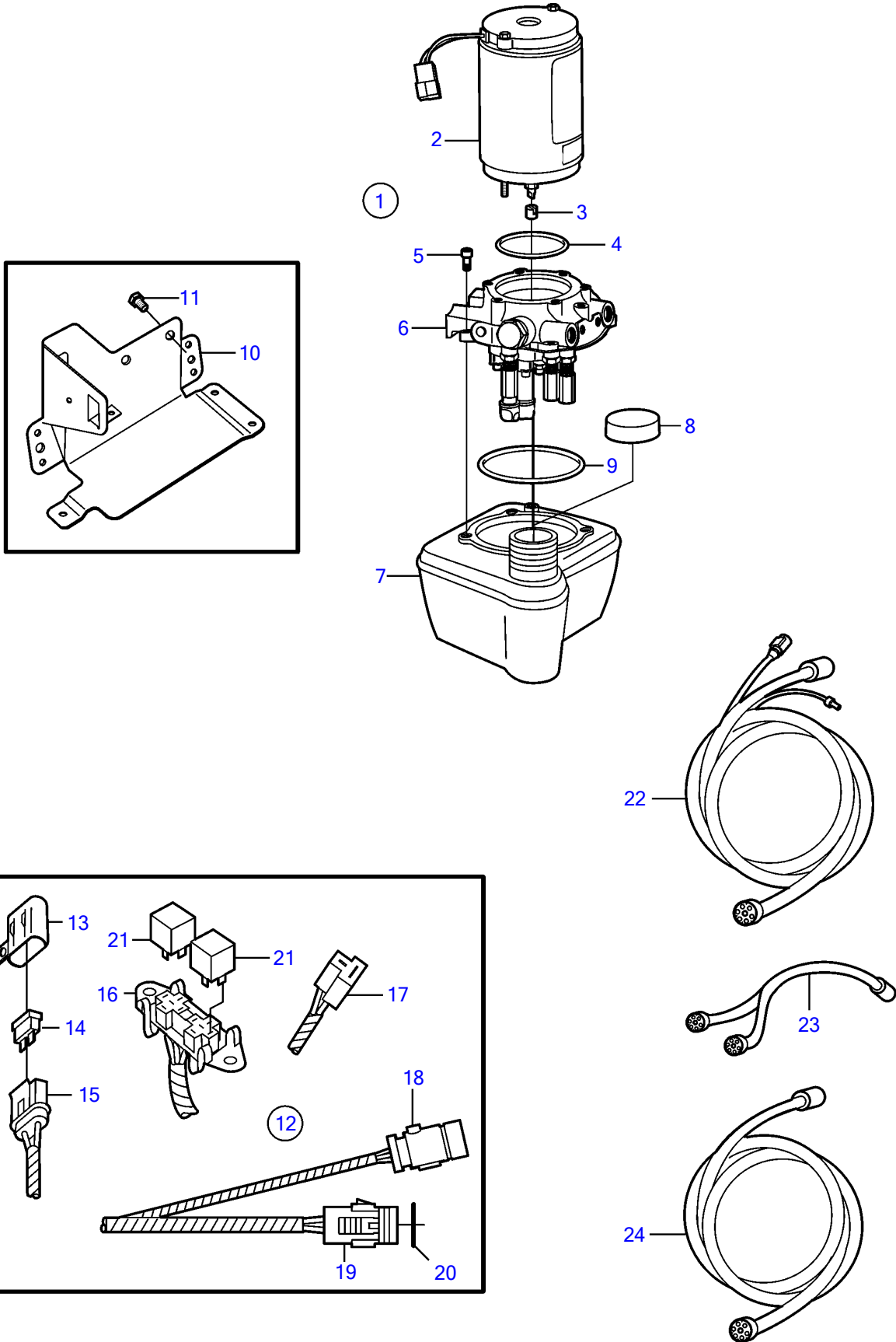

## X-B, X-BLT

REF	PART NO.	QTY	DESCRIPTION	NOTES
1	3860372	1	Pump, trim	
2	3861576	1	• Electrical motor	
3	3861577	1	• Connector	
4	3861578	1	• O-ring	
5	3861574	4	• Screw	
6		1	• Valve body	Not serviced
7	3861570	1	• Reservoir	
8	3861572	1	• • Cardboard tube	
9	3861573	1	• • O-ring	
10	3858083	1	• Bracket	
11	971017	2	• Hexagon screw	
12	3857345	1	• Wiring harness	
13	8072808	1	• • Cover	
14	967545	1	• • Fuse	10 amp
15	8166029	1	• • Insulator	
	(3852254)	2	• • Terminal	Obsolete part
16	(3852210)	1	• • Bracket	Obsolete part
	(3852246)	4	• • Terminal	Obsolete part
	(3852247)	6	• • Terminal	Obsolete part
17	958210	1	• • Housing	
	(3852247)	2	• • Terminal	Obsolete part
18		1	• • Connector	Not serviced
19	(3852250)	1	• • Terminal	Obsolete part
	3852251	1	• • Plug	
	(3852253)	2	• • Terminal	Obsolete part
20	3852537	1	• • O-ring	
21	3858809	2	• Relay	
22	3855709	X	Wiring harness, trim	5m
	3855708	X	Wiring harness, trim	7m
23	3855712	X	Wiring harness, y	Dual station
24	3855710	X	Wiring harness, extension	3m
	3855711	X	Wiring harness, extension	5m